

## LD31, LD32, LD33 and LD36 Series Manual



©2025 Flowline, Inc.  
All Rights Reserved

# Table of Contents

---

The DeltaSpan™ LD31 Series General Purpose Clean Water & Oil, LD32 Series General Purpose Pump Lift Station or LD33 Series Anti-Corrosion pressure liquid level transmitters or LD36 series temperature and pressure liquid level transmitters are manufactured for years of trouble free service in the harshest applications. The pressure transmitter measures the height of liquid above the position in the tank referenced to atmospheric pressure. The transmitter consists of a piezoresistive sensing element, encased in 316 SS housing. The LD31, LD33 and LD36 series features a bullet nose design protects the diaphragm from damage while the LD32 series features a large diameter 316 SS diaphragm seal is non-clogging and damage resistant to floating solids.

## NEW FEATURES

- Excellent chemical compatibility with 316L SS or PTFE construction
- Lightning and surge protection on all models
- Maintenance free vent filter
- Combination of Pressure and Temperature in the LD36 Series

## TABLE OF CONTENTS

<b>Step One   Introduction:</b> .....	<b>3</b>
Specifications: .....	3
Dimensions: .....	4
<b>Step Two   Safety Precautions:</b> .....	<b>6</b>
Components: .....	7
<b>Step Three   Getting Started:</b> .....	<b>8</b>
Pressure Transmitter Basics: .....	8
How to Convert Pressure into Liquid Height?: .....	9
How to Calculate Maximum Liquid Height (MLH)?:.....	9
How to Select the Correct Pressure Transmitter?:.....	9
How Does Specific Gravity affect Pressure Transmitters?:.....	10
<b>Step Four   Wiring:</b> .....	<b>11</b>
Common Wiring to Displays, Controllers & PLCs: .....	11
Temperature Output (LD36 Series Only): .....	13
Electrical Installation: .....	13
<b>Step Five   Installation:</b> .....	<b>14</b>
Mounting Tools: .....	15
<b>Step Six   Configuration with Display:</b> .....	<b>16</b>
How to Configure to a DataView™ or DataLoop™ Series (Method #1): .....	17
Configure the DataView™ LI55 Series (Method #1): .....	18
Configure the DataLoop™ LI23/LI24 Series (Method #1): .....	19
How to Configure to a DataView™ or DataLoop™ Series (Method #2): .....	20
Configure the DataView™ LI55 Series (Method #2):.....	21
Configure the DataLoop™ LI23/LI24 Series (Method #2): .....	22
<b>Step Seven   Maintenance:</b> .....	<b>23</b>
Testing the Transmitter: .....	23
Desiccant Filter (Optional): .....	23
<b>Step Eight   Warranty:</b> .....	<b>24</b>

**SPECIFICATIONS**

Range:	-SX01: 0 to 5 psi (0.34 bar), 0 to 11' (0 to 3.4m) water column (WC) -SX11: 0 to 10 psi (0.69 bar), 0 to 23' (0 to 7m) water column (WC) -SX21: 0 to 15 psi (1.0 bar), 0 to 34' (0 to 10.4m) water column (WC) -SX31: 0 to 20 psi (1.38 bar), 0 to 46' (0 to 14m) water column (WC)
Accuracy:	-SX01: $\pm 0.5\%$ of full scale -SX11, -SX21, -SX31: $\pm 0.25\%$ of full scale
Configuration:	None, fixed span
Supply voltage:	11 to 28 VDC
Loop resist.:	900 Ohms @ 28 VDC
Signal output:	4-20 mA, two-wire
Process temp.:	F: 14° to 176°, C: -10° to 80°
Storage temp.:	F: -40 to 212°, C: -40 to 100°
Temp. Range:	LD36 only: F: -40 to 257°, C: -40 to 125°
Burst pressure:	2 x full scale
Response time:	50 ms
Weight:	LD31: 1.8 lb (0.82 kg) LD32: 4.3 lb (1.95 kg) LD33: 1.9 lb. (0.86 kg) LD36: 2.35 lb. (1.07 kg)
Sensor material:	LD31, LD32 & LD36: 316L SS Housing w/ 316L SS Diaphragm LD33: PTFE Housing w/ Ceramic Diaphragm
Cable type:	2-conductor, shielded with vent tube
Cable length:	-SX01 & SX11: 40' (12.2m), -SX21 & SX31: 60' (18.3m)
Cable material:	LD31, LD32 & LD36: Polyurethane LD33: Teflon
Classification:	General purpose
Compliance:	CE

**DIMENSIONS**

**LD31 Series**

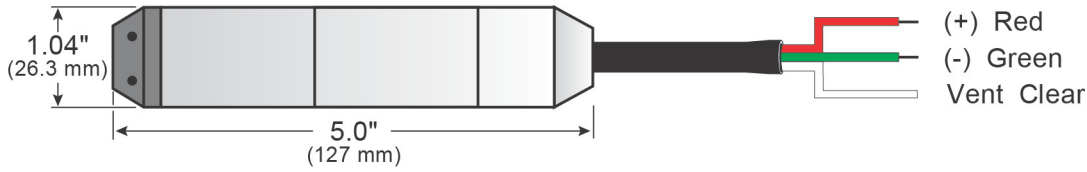

**LD32 Series**

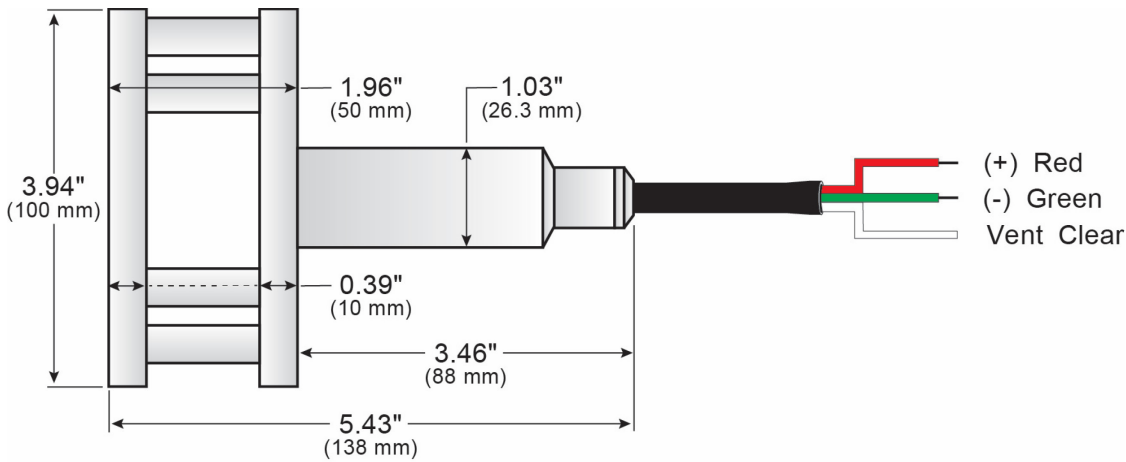

**LD90 Series**

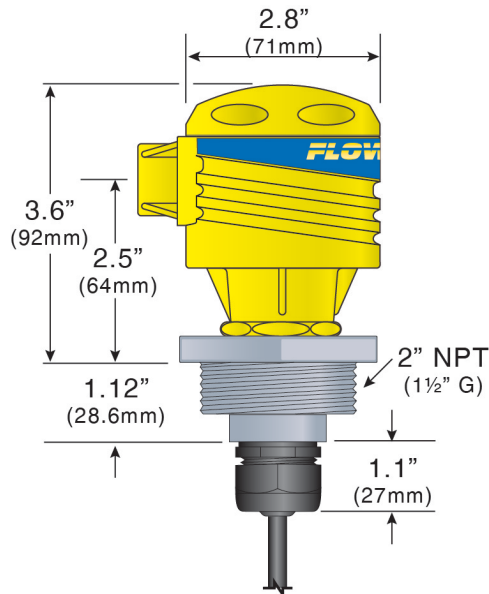

**LM50-5000 Cable Hanger**

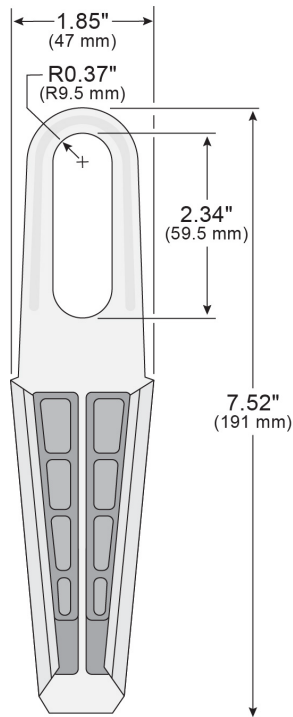

**DIMENSIONS**

**LD33 Series**

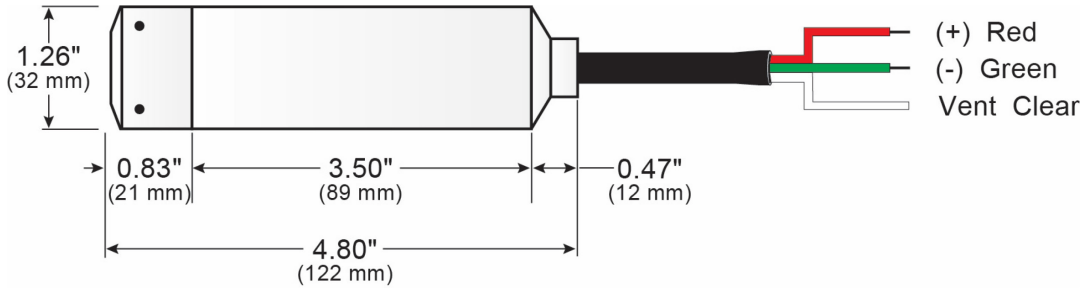

**LD36 Series**

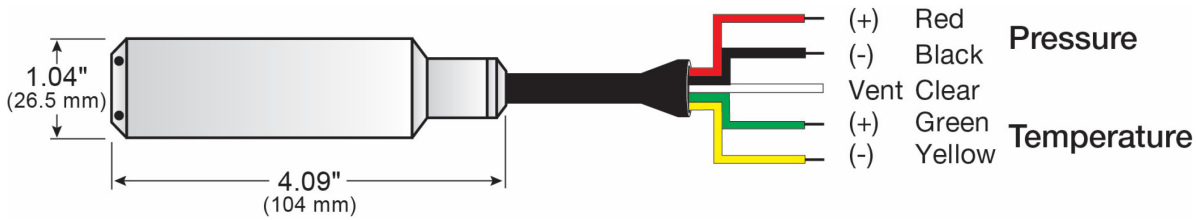

**LD90 Series**

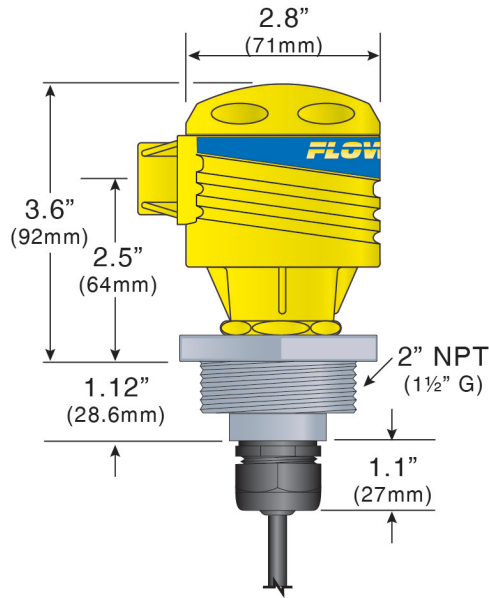

**LM50-5000 Cable Hanger**

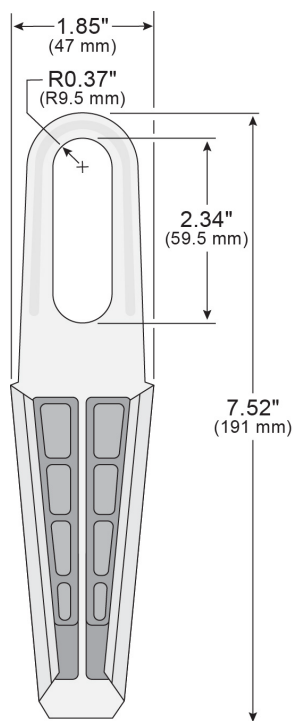

- ⚠ **About this Manual:** PLEASE READ THE ENTIRE MANUAL PRIOR TO INSTALLING OR USING THIS PRODUCT. This manual includes information on the DeltaSpan™ Series Pressure Liquid Level Transmitter from FLOWLINE. Please refer to the part number located on the switch label to verify the exact model configuration, which you have purchased.
- ⚠ **User's Responsibility for Safety:** Flowline manufactures a broad range of level sensing technologies. While each of these sensors is designed to operate in a wide variety of applications, it is the user's responsibility to select a sensor model that is appropriate for the application, install it properly, perform tests of the installed system, and maintain all components. The failure to do so could result in property damage or serious injury.
- ⚠ **Proper Installation and Handling:** Only professional staff should install and/or repair this product. Use a proper sealant with all installations. Always check for leaks prior to system start-up.
- ⚠ **Wiring and Electrical:** A supply voltage of 11 to 28 VDC is used to power the DeltaSpan™. Electrical wiring of the transmitter should be performed in accordance with all applicable national, state, and local codes.
- ⚠ **Material Compatibility:** The LD31, LD32 and LD36 series are made of 316 Stainless Steel (316 SS) with a cable of Polyurethane. The LD31 series has a bullet nose of Buna-N. The LD33 series is made of PTFE (polytetrafluoroethylene) with a cable made of FEP (fluorinated ethylene propylene). Make sure that the model which you have selected is chemically compatible with the application liquids.
- ⚠ **Handling Static-Sensitive Circuits/Devices:** When handling the transmitter, the technician should follow these guidelines to reduce any possible electrostatic charge build-up on the technician's body and the electronic part.
  1. Always touch a known good ground source before handling the part. This should be repeated while handling the part and more frequently after sitting down from a standing position, sliding across the seat or walking a distance.
  2. Avoid touching electrical terminals of the part unless making connections.
- ⚠ **Make a Fail-Safe System:** Design a fail-safe system that accommodates the possibility of switch and/or power failure. FLOWLINE recommends the use of redundant backup systems and alarms in addition to the primary system.
- ⚠ **Flammable, Explosive or Hazardous Applications:** DeltaSpan™ should not be used within classified hazardous environments.

**COMPONENTS**

DeltaSpan™ is offered in four different models. Depending on the model purchased, you may or may not have been shipped all the components shown below.

**DeltaSpan™ General Purpose Clean Water, Chemicals & Oil (LD31 Series)**

Part Number	Max. Pressure	Range in Water Column (WC)	Cable Length
LD31-S101	05 psi	11.54 ft WC / (3.52 m WC)	40' (12.2 m)
LD31-S111	10 psi	23.09 ft WC / (7.04 m WC)	40' (12.2 m)
LD31-S121	15 psi	34.63 ft WC / (10.56 m WC)	60' (18.3 m)

**DeltaSpan™ General Purpose Pump Lift Station (LD32 Series)**

Part Number	Max. Pressure	Range in Water Column (WC)	Cable Length
LD32-S101	05 psi	11.54 ft WC / (3.52 m WC)	40' (12.2 m)
LD32-S111	10 psi	23.09 ft WC / (7.04 m WC)	40' (12.2 m)
LD32-S121	15 psi	34.63 ft WC / (10.56 m WC)	60' (18.3 m)

**DeltaSpan™ General Purpose Anti-Corrosion PTFE (LD33 Series)**

Part Number	Max. Pressure	Range in Water Column (WC)	Cable Length
LD33-S101	05 psi	11.54 ft WC / (3.52 m WC)	40' (12.2 m)
LD33-S111	10 psi	23.09 ft WC / (7.04 m WC)	40' (12.2 m)
LD33-S121	15 psi	34.63 ft WC / (10.56 m WC)	60' (18.3 m)

**DeltaSpan™ General Purpose Clean Water, Chemicals & Oil w/ Temperature (LD36 Series)**

Part Number	Max. Pressure	Range in Water Column (WC) / Temperature Output Range	Cable Length
LD36-S121	15 psi	34.63 ft WC / (10.56 m WC) / F: -40 to 257°, C: -40 to 125°	60' (18.3 m)

**PRESSURE TRANSMITTER BASICS**

DeltaSpan™ pressure liquid level transmitter's are all fixed span devices. The 4-20mA output cannot be changed or adjusted. Because of this fact, **ALL CONFIGURATIONS** are performed within the local display or controller and are designed to match the span of the pressure sensor. This document will assist in configuring the Flowline DataView™ (LI55 series) or DataLoop™ (LI23 and LI24 series) with a pressure transmitter.

**DataView™ LI55 series**



**DataLoop™ LI23 or LI24 series**



If a pressure transmitter is properly selected, then the 20mA output of the sensor will be above the Full liquid level (see below). 4mA will always be be where the sensor is placed. If the sensor rests on the bottom of the tank, then the centerline of the sensor will be where the 4mA is located.

**Sensor Resting on Bottom of Tank**

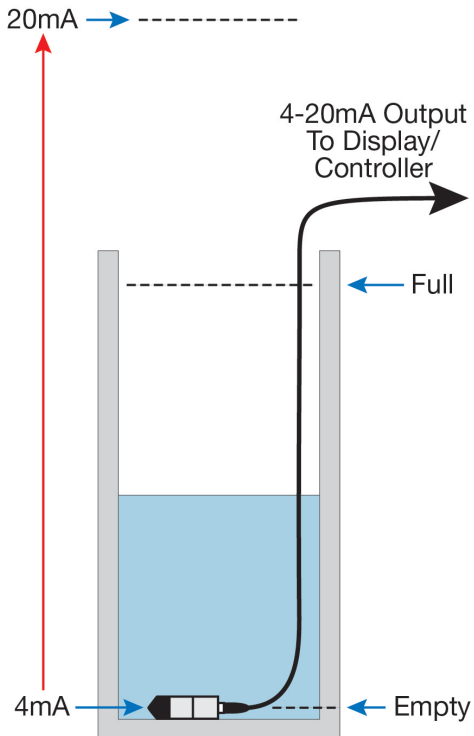

**Sensor offset from Bottom of Tank**

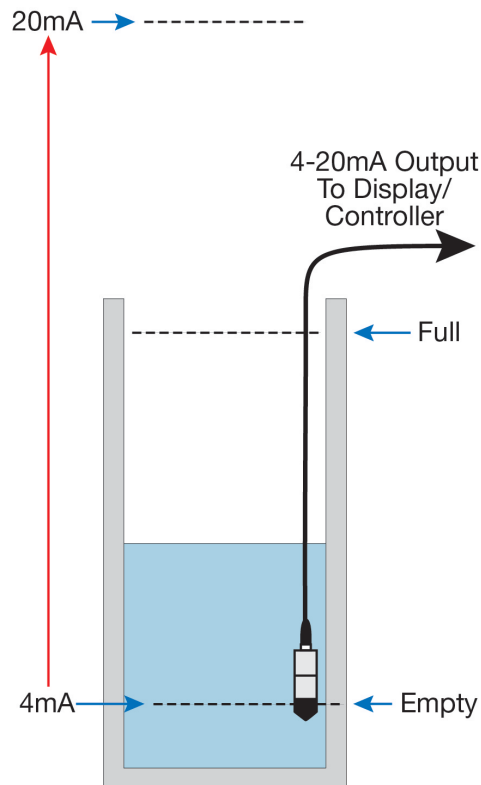



**HOW TO CONVERT PRESSURE INTO LIQUID HEIGHT?**

Pressure transmitters are all defined by the pressure range and not by Liquid Height. To convert pressure to **Liquid Height**, use the following ratio:

$1 \text{ psi} = 2.31 \text{ feet of water}$	$1 \text{ psi} = 0.704 \text{ meters of water}$
Therefore, a <b>15 psi</b> transmitter will have a <b>Liquid Height = 34.65 feet (10.56m)</b> :	
$15 \text{ psi} \times 2.31' / \text{psi} = 34.65'$	$15 \text{ psi} \times 0.704 \text{ m} / \text{psi} = 10.56\text{m}$

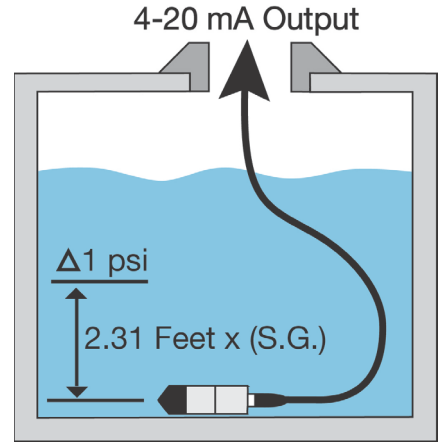

With the above ratio, you can always find the Liquid Height or water column (WC) of any pressure transmitter.

**HOW TO CALCULATE MAXIMUM LIQUID HEIGHT (MLH)?**

To calculate the **Maximum Liquid Height (MLH)** of a sensor, use the following formula:

<b>Feet</b>	$\text{Maximum Liquid Height (MLH)} = (\text{Pressure Range} \times 2.31) / \text{SG}$
<b>Meters</b>	$\text{Maximum Liquid Height (MLH)} = (\text{Pressure Range} \times 0.704) / \text{SG}$

Example: **15 psi** transmitter installed in a liquid with a **SG=0.9** will have the following value(s):

<b>Feet</b>	$\text{MLH} = (15 \text{ psi} \times 2.31' / \text{psi}) / 0.9 = 38.5'$
<b>Meters</b>	$\text{MLH} = (15 \text{ psi} \times 0.704\text{m} / \text{psi}) / 0.9 = 11.73\text{m}$

**Note:** The above formulas will always provide the **MLH** for any pressure transmitter.

**HOW TO SELECT THE CORRECT PRESSURE TRANSMITTER?**

The objective is to select a sensor with a **MLH** that will cover the entire application span. If the liquid height of the tank is greater the sensor's **MLH**, then the sensor will not be able to read a full tank level. The **MLH** does not have to equate to the liquid height, it just needs to be greater than the liquid height (never less than).

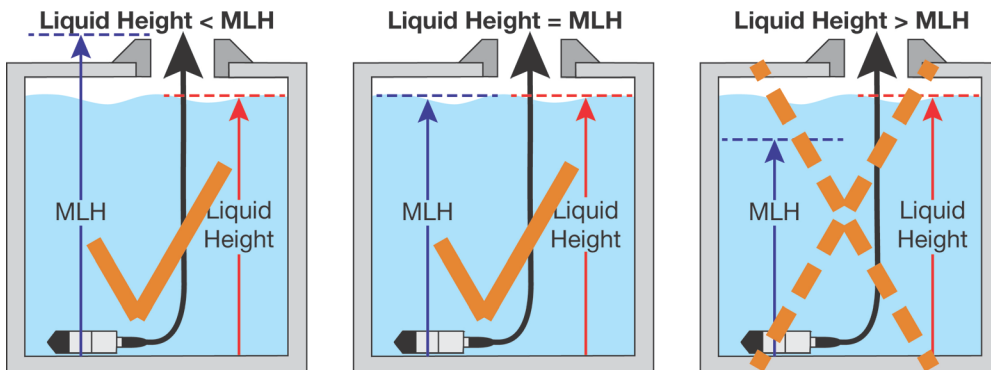

**HOW DOES SPECIFIC GRAVITY AFFECT PRESSURE TRANSMITTERS?**

The Specific Gravity (SG) of a liquid will not change the pressure of the transmitter but will affect how the transmitter reads the liquid height. Remember, liquids with a SG < 1.0 are lighter than water and liquids with a SG > 1.0 are heavier than water. **Water has a SG = 1.0.**

A SG < 1.0 requires more liquid (a taller water column) to equal the same pressure as with water.	A SG > 1.0 requires less liquid (shorter water column) to equal the same pressure as with water.
---	--

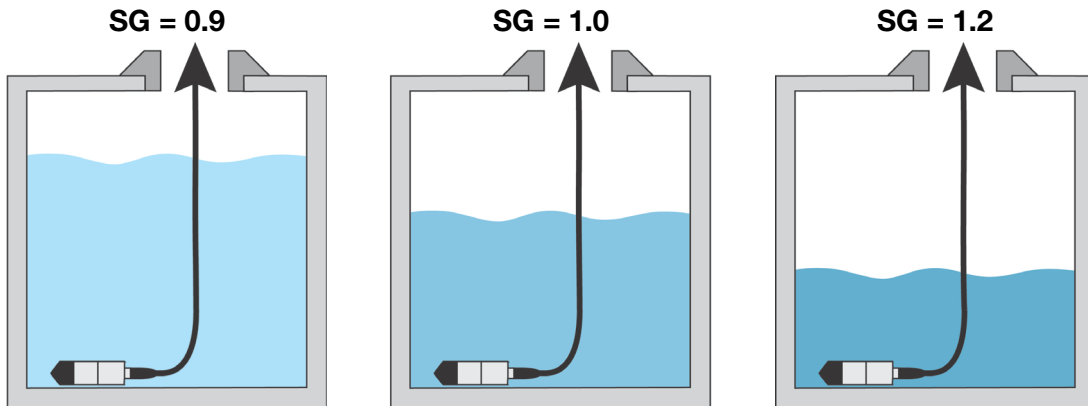

Example: Compare the **Maximum Liquid Height** of a liquid with SG = 0.9, 1.0 and 1.2 using a transmitter with 15 psi pressure range (PR).

SG	Feet	Meters
0.9	$MLH = (PR \times 2.31) / SG$ $= (15 \text{ psi} \times 2.31' / \text{psi}) / 0.9$ $= 38.5'$	$MLH = (PR \times 0.704) / SG$ $= (15 \text{ psi} \times 0.704 \text{m} / \text{psi}) / 0.9$ $= 11.73 \text{ m}$
1.0	$MLH = (PR \times 2.31) / SG$ $= (15 \text{ psi} \times 2.31' / \text{psi}) / 1.0$ $= 34.65'$	$MLH = (PR \times 0.704) / SG$ $= (15 \text{ psi} \times 0.704 \text{m} / \text{psi}) / 1.0$ $= 10.56 \text{ m}$
1.2	$MLH = (PR \times 2.31) / SG$ $= (15 \text{ psi} \times 2.31' / \text{psi}) / 1.2$ $= 28.88'$	$MLH = (PR \times 0.704) / SG$ $= (15 \text{ psi} \times 0.704 \text{m} / \text{psi}) / 1.2$ $= 8.80 \text{ m}$

**Note:** Identifying the correct specific gravity for the fluid is critical in understanding the operational range of the pressure transmitter.

**COMMON WIRING TO DISPLAY, CONTROLLERS AND PLCs:**

**Wiring to a Loop Powered Display:**

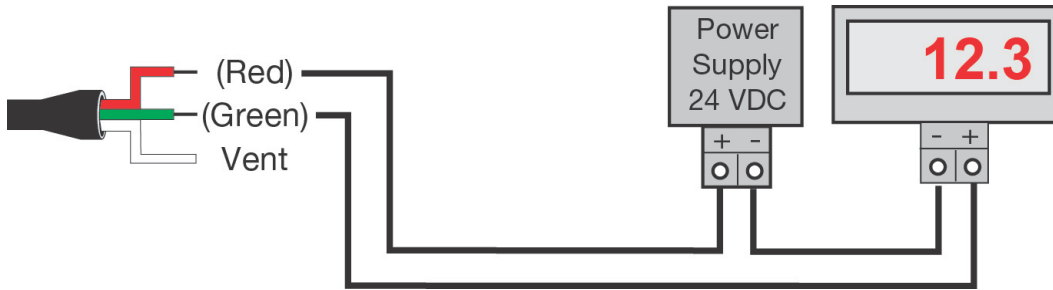

**Wiring to a Generic PLC:**

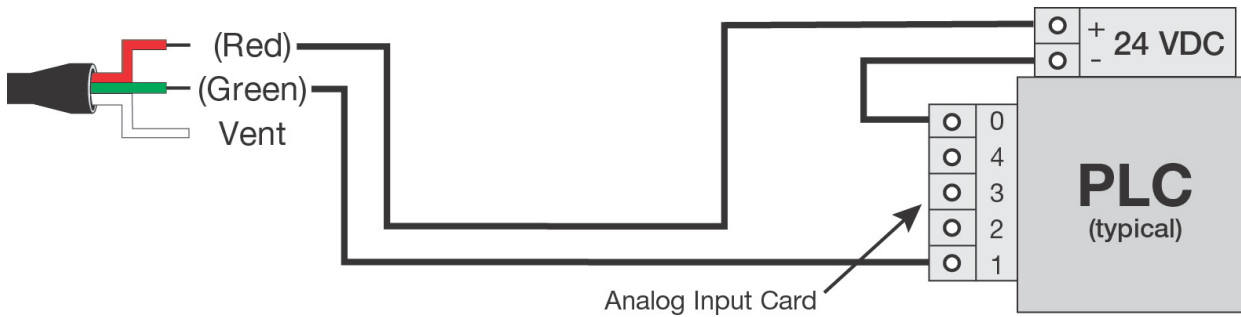

**Wiring to the DataView™ LI55 Series Level Controller:**

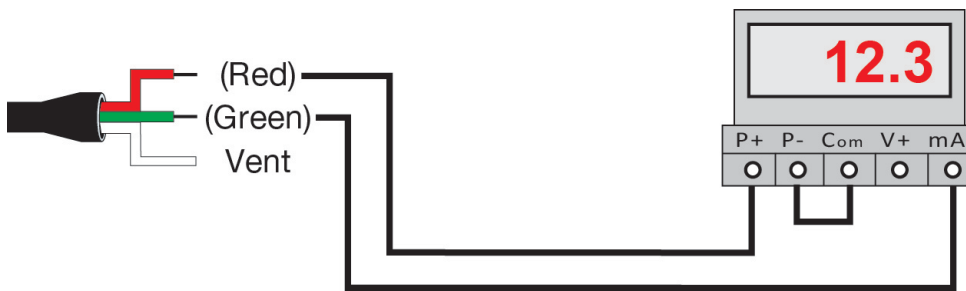

**COMMON WIRING TO DISPLAY, CONTROLLERS AND PLCs:**

**Wiring to the DataPoint™ LC52 Series Level Controller:**

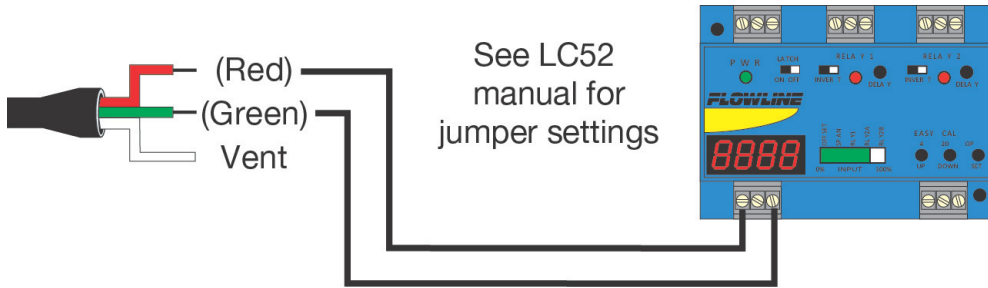

*JWA mode (Factory Setting)*

**Wiring to a DataLoop™ LI23 Series Level Indicator without the Backlight:**

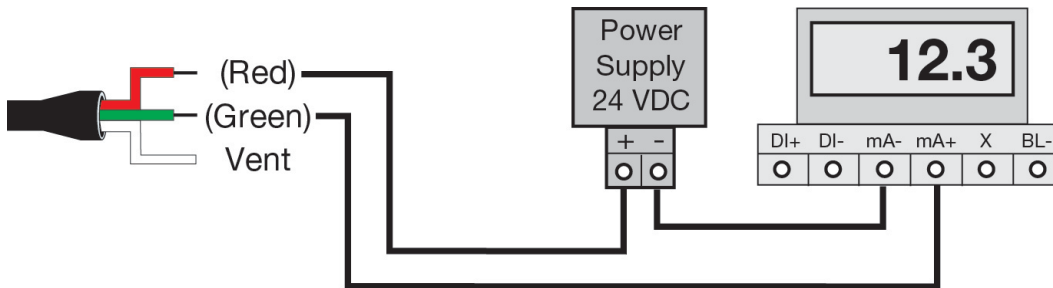

*(Note: the LI25 Series without backlight will have an added 1.5 VDC voltage drop)*

**Wiring to a DataLoop™ LI23 Series Level Indicator with the Backlight:**

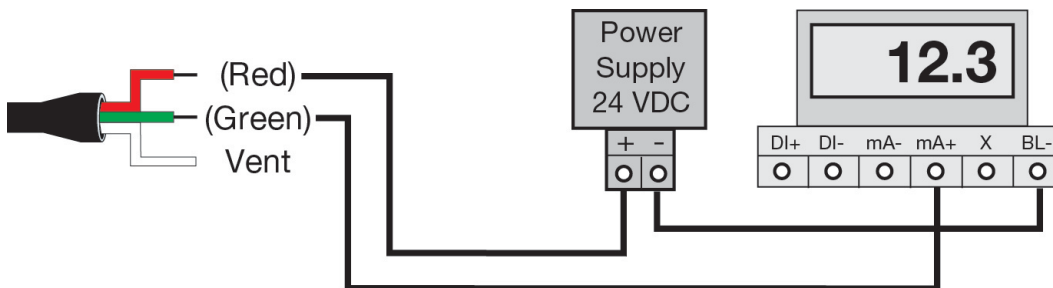

*(Note: the LI23 Series without backlight will have an added 4.5 VDC voltage drop)*

**TEMPERATURE OUTPUT (LD36 SERIES ONLY):**

The LD36 series includes a second 4-20mA output that will measure the temperature of the liquid around the sensor.

Both outputs are loop powered with Red and Black wires for the level output and Green and Yellow wires for the temperature output.

The temperature output is scaled with 4mA = -40 °F (-40 °C) and 20mA = 257 °F (125 °C).

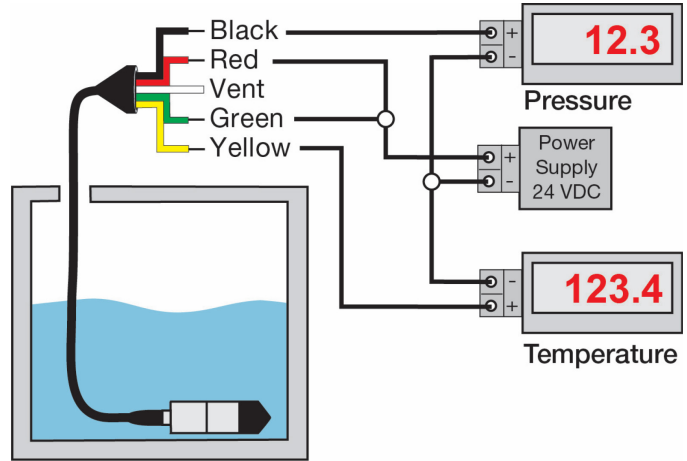

**ELECTRICAL INSTALLATION:**

**Wire Length** - The maximum length of wire connecting the transmitter and receiver is a function of wire size and receiver resistance. Wiring should not contribute more than 10% of the receiver resistance to total loop resistance. For extremely long runs (over 1000 feet), choose receivers with higher resistance to minimize the size and cost of connecting leads. Where wiring length is less than 100 feet, wire as small as 22 AWG can be used.

**Wiring** - An external power supply delivering 11-28 VDC for the LD31, LD32, LD33 and LD36 series with minimum current capability of 40 mA DC (per transmitter) is required to power the control loop. See Fig. A for connection of the power supply, transmitter and receiver. The range of appropriate receiver load resistance (RL) for the DC power supply voltage available is expressed by the formula:

$$RL_{max} = (V_{sup} - 10V) / 20 \text{ mA DC}$$

- **Shielded cable is recommended for control loop wiring.**
- **Use the wires in the table below for testing the 4-20mA loop output.**

Series	LD31-S1_1	LD32-S1_1	LD33-S1_1	LD36-S121	
Type	Pressure				Temperature
Positive (+)	Red Wire	Red Wire	Red Wire	Red Wire	Green Wire
Negative (-)	Green Wire	Green Wire	Green Wire	Black Wire	Yellow Wire

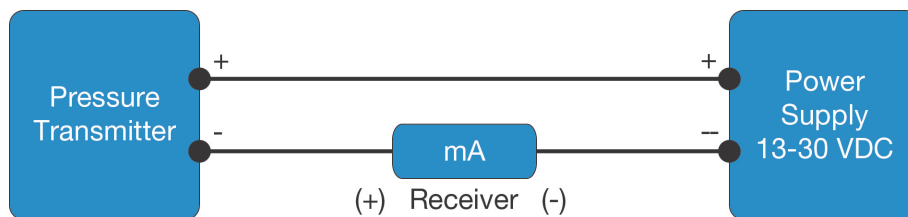
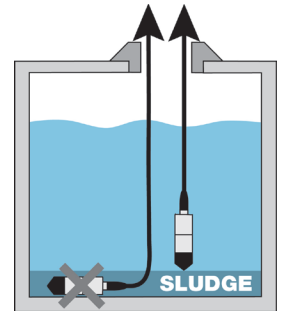

Fig. A

All models are designed to operate while submerged in the actual application liquid. Avoid installing the level transmitter along the bottom of the tank in materials such as sludge that can build up and coat/cover the transmitter. This also includes any debris that will settle along the bottom of the tank. In these applications, it is best to suspend the transmitter above the highest level of sludge/debris that will occur.



1. **Location:** Select a location where the temperature of the transmitter will be within the specification of the sensor (see specification page). Distance from the receiver is limited only by total loop resistance.
2. **Position:** The transmitter is not position sensitive. However all standard models are originally calibrated with the unit in a position with the pressure connection downward. Although they can be used at other angles, for best accuracy it is recommended that units be installed in the position calibrated at the factory.
3. **Mounting:** The transmitter can be mounted via several methods. It can be suspended from the electrical cable, it can be placed resting on the bottom of the tank in either horizontal or vertical orientation, or it can be attached to a hang wire.

**Interference:** The DeltaSpan™ is designed to operate under the surface of the liquid in the tank. Avoid installations where other tank requirements will cause the transmitter to move or swing.

**Example:** A mixer blade could cause the level transmitter to whip around within the tank. An alternative would be to move the transmitter to a more stable section of the tank or to install the LD31 series inside a still well/drop tube. The still well/drop pipe will minimize the effects created by the mixer.

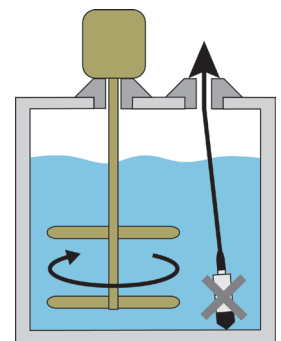

**Termination:** The cable for the DeltaSpan™ is typically terminated at a junction box located on top of the tank. Since the vent tube is contained within the cable, the pressure within the junction box must always be the same as the reference (typically atmospheric) pressure for the liquid. The inside of the junction box must be clean, dry and free of moisture. Add the optional pressure fitting (LD90-\_0\_1) to complete the package. The LD90-\_0\_1 features a 2" NPT or 1½" G thread for mounting and a liquid tight connector to seal the cable interface.

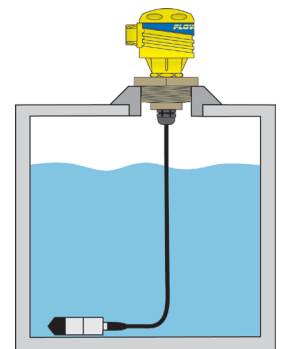

**Note:** Use caution when sealing the cable at the top of the tank. The ventilation tube must be open and free to allow air to flow back to the pressure diaphragm. Avoid blocking the ventilation tube by compressing the cable. Always keep the cable termination clean, dry and free of moisture and prevent liquid from entering the vent tube.

**Note:** A vent Filter is provided on the end of the vent tube. If the application requires the vent tube to be cut to length, then remove the vent filter and place on the end of the new end of the vent tube.

## MOUNTING TOOLS:

There are many ways to mount a submersible pressure transmitter including the LD90 series Pressure Sensor Mounting Kit or the LM50 series (LM50-5000) Mounting Hanger. Both systems hold the cable for the transmitter. The LD90 series is attached via a 2" NPT or 1.5" G thread while the LM50 series is attached to a clip, hook, ring or any object at the top of the tank.

### LD90 series Pressure Sensor Mounting Kit

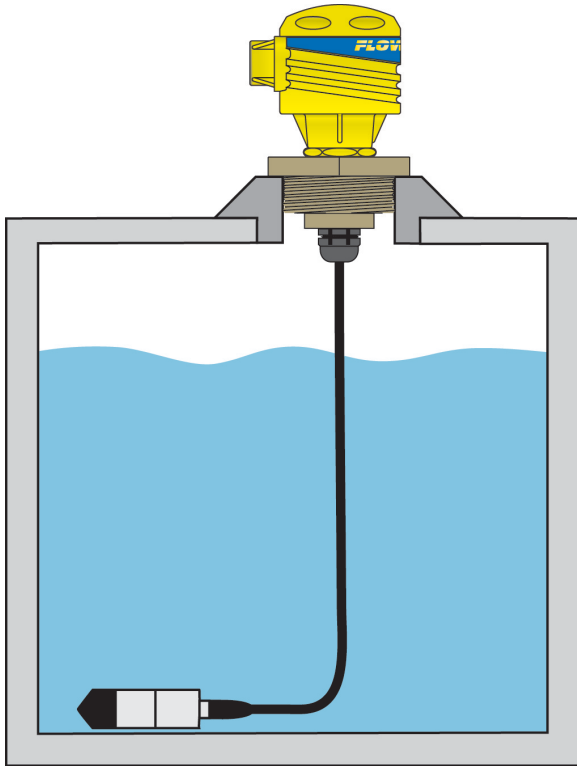

### LM50 series (LM50-5000) Mounting Hanger

Works with cable OD (5.5 to 10.5mm)

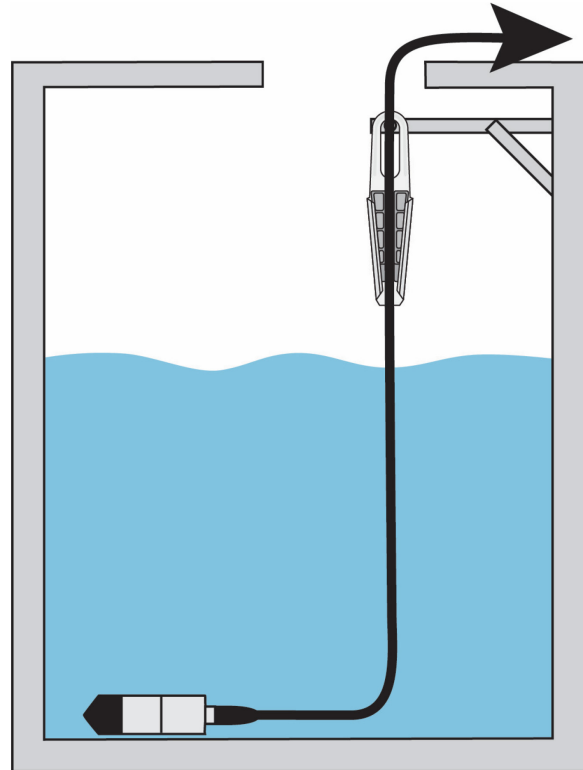

**METHODS TO CONFIGURE WITH DISPLAY/CONTROLLER:**

There are two methods to configure the DeltaSpan™ to a local Display or local Controller

**Method #1** – Use the existing span of the Pressure Transmitter to match a virtual tank that extends above a Full Tank. Even though this implies a much taller tank, as long as all of your controls for any pumps, valves or alarms are set within the actual Full level of the tank, then you will not see any difference in tank level performance.

**Method #2** – Ignore the fixed 4-20mA span of the Pressure Transmitter and Calculate the Current at a Full Liquid Level. This current will be the new full span for the Display or Controller. All controls for any pumps, valves or alarms are also set within the actual Full level of the tank. You will not lose any accuracy when spanning to a smaller current range.

***This Method is the easiest to configure.***

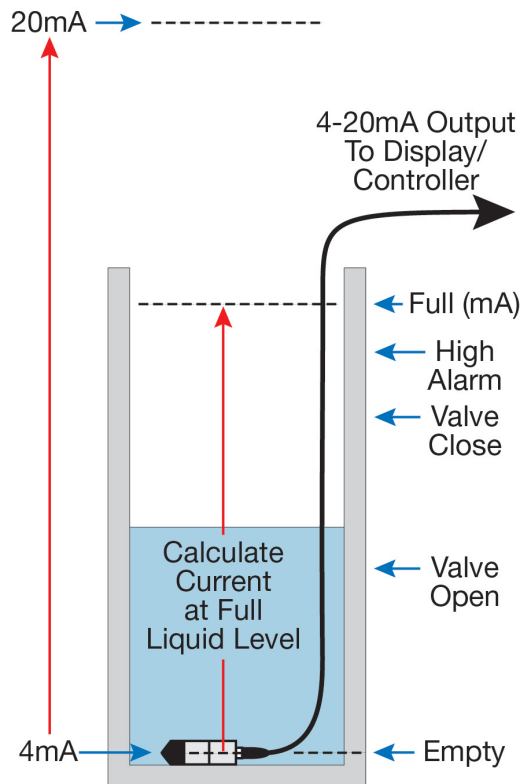
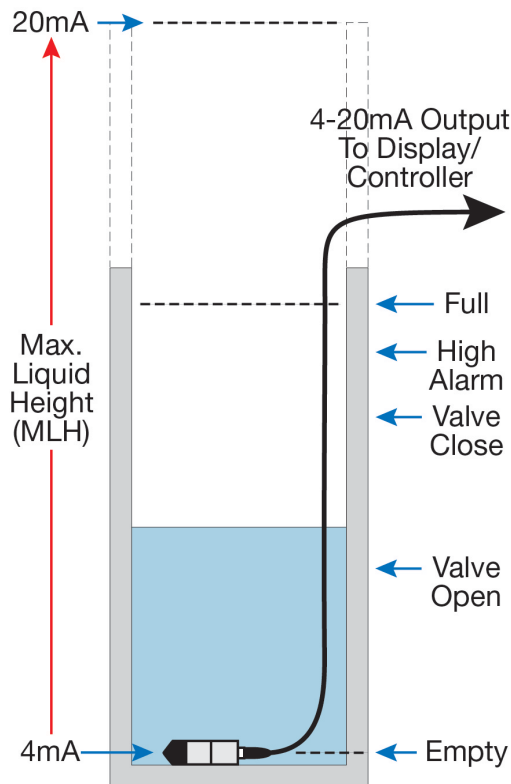



**HOW TO CONFIGURE TO A DATAVIEW™ OR DATALOOP™ (METHOD #1):**

To span DataView™ or DataLoop™ to the full span of the pressure sensor, you need the following information:

- Pressure Range (**PR**) of the sensor in psi
- Specific Gravity (**SG**) of the liquid
- Units of operation (**Feet** or **Meters**)
- Maximum Liquid Height (**MLH**)
  - This is the equivalent height of liquid (in a virtual tank) at the full span of the transmitters (at 20mA)

To calculate the **Maximum Liquid Height (MLH)** of a sensor, use the following formulas:

Feet	$MLH = ( PR \times 2.31 ) / SG$
Meters	$MLH = ( PR \times 0.704 ) / SG$

Example: **15 psi** transmitter installed in a liquid with a **SG=0.9** will have the following value(s):

Feet	$MLH = ( 15 \text{ psi} \times 2.31' / \text{psi} ) / 0.9 = 38.5'$
Meters	$MLH = ( 15 \text{ psi} \times 0.704\text{m} / \text{psi} ) / 0.9 = 11.73\text{m}$

- Pump, Valve and Alarm setpoints
  - All set points are in either Feet of Meters of liquid and are measure from the location of the Pressure Transmitter.

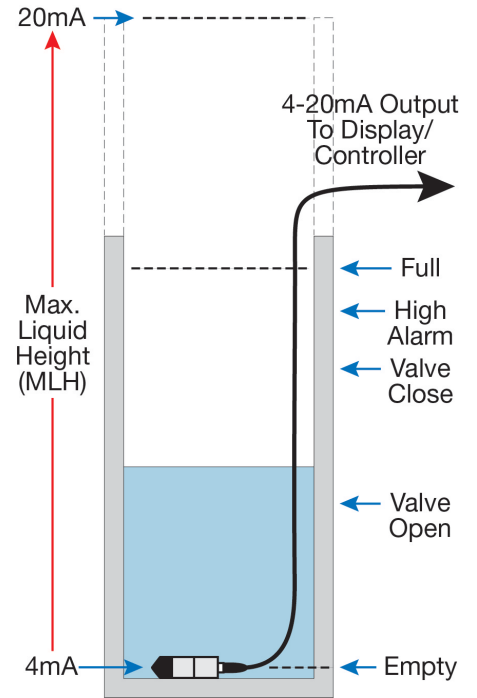

## CONFIGURE THE DATAVIEW™ LI55 SERIES (METHOD #1):

Use the following steps to configure the DataView™ to match the DeltaSpan™ transmitter:

1. Set UNITS (**unitsS**) to Feet or Meters
2. Set DECIMAL POINT (**dEc Pt**) to dddd.dd
3. Set SCALE to the following:
  - a. Set Empty (**EmPtY**) to 0 feet (or 0 meters) of liquid.
  - b. Set Full (**FuLL**) to the Maximum Liquid Height (**MLH**).
4. Set RELAYS (**rELAY**) to liquid levels where the relay will close and open
  - a. Each relay will have a setting where the relay will energize (**SEt 1** for relay 1, etc.) and a setting where the relay will de-energize (**RSt 1** for relay 1, etc.).
    - i. High alarms – Set **SEt #** at the level for the high alarm and set **RSt #** to a level slightly below the SEt #. This will create a small hysteresis to prevent chatter (i.e. SEt 2 = 8.00' and RSt 2 = 7.90'...this creates a 0.10' hysteresis).
    - ii. Low alarms – Set **SEt #** at the level for the low alarm and set **RSt #** to a level slightly above the SEt #. This will create a small hysteresis to prevent chatter (i.e. SEt 3 = 2.00' and RSt 3 = 2.15'...this creates a 0.15' hysteresis).
    - iii. Valve or Pump Fill - Set **SEt #** at the level for the Valve to Open or the Pump to Start Filling and set **RSt #** at the level above where the valve will Close or the pump will Stop Filling. This will create a unique ON and OFF span (i.e. SEt 4 = 3.00' and RSt 3 = 7.50'...this creates a fill span of 4.50').
    - iv. Valve or Pump Empty - Set **SEt #** at the level for the Valve to Open or the Pump to Start Emptying and set **RSt #** at the level below where the valve will Close or the pump will Stop Emptying. This will create a unique ON and OFF span (i.e. SEt 1 = 7.00' and RSt 1 = 4.00'...this creates a empty span of 3.00').



## CONFIGURE THE DATALOOP™ LI23/LI24 SERIES (METHOD #1):

Use the following steps to configure the DataLoop™ to match the DeltaSpan™ transmitter:

1. Set UNITS (**unitsS**) to Feet or Meters
2. Set DECIMAL POINT (**dEc Pt**) to dddd.dd
3. Set SCALE to the following:
  - a. Set Input 1 (**InPt 1**) to 04.000 mA (*default is 04.000, so no changes are required*).
  - b. Set Display 1 (**DSPY 1**) to +00,000.00 (*default is +00,000.00, so no changes are required*).
  - c. Set Input 2 (**InPt 2**) to 20.000 mA (*default is 20.000, so a change is required*).
  - d. Set Display 2 (**DSPY 2**) to Maximum Liquid Height (**MLH**) value (*default is +00,100.00, so a change is required*).
4. Set RELAYS (**rELAY**) to liquid levels where the relay will close and open
  - a. Each relay will have a setting where the relay will energize (**SEt #** for relay 1, etc.) and a setting where the relay will de-energize (**RSt #** for relay 1, etc.).
    - i. High alarms – Set **SEt #** at the level for the high alarm and set **RSt #** to a level slightly below the SEt #. This will create a small hysteresis to prevent chatter (i.e. SEt 2 = 8.00' and RSt 2 = 7.90'...this creates a 0.10' hysteresis).
    - ii. Low alarms – Set **SEt #** at the level for the low alarm and set **RSt #** to a level slightly above the SEt #. This will create a small hysteresis to prevent chatter (i.e. SEt 3 = 2.00' and RSt 3 = 2.15'...this creates a 0.15' hysteresis).
    - iii. Valve or Pump Fill - Set **SEt #** at the level for the Valve to Open or the Pump to Start Filling and set **RSt #** at the level above where the valve will Close or the pump will Stop Filling. This will create a unique ON and OFF span (i.e. SEt 4 = 3.00' and RSt 3 = 7.50'...this creates a fill span of 4.50').
    - iv. Valve or Pump Empty - Set **SEt #** at the level for the Valve to Open or the Pump to Start Emptying and set **RSt #** at the level below where the valve will Close or the pump will Stop Emptying. This will create a unique ON and OFF span (i.e. SEt 1 = 7.00' and RSt 1 = 4.00'...this creates a empty span of 3.00').



HOW TO CONFIGURE TO A DATAVIEW™ LI55 SERIES (METHOD #2):

To span DataView™ to match the physical span of tank, you will need the following information:

- Pressure Range (**PR**) of the sensor in psi
- Hight of Tank (**FULL**) in feet or meters
- Specific Gravity (**SG**) of the liquid
- Units of operation (**Feet** or **Meters**)
- Maximum Liquid Height (**MLH**)
  - This is the equivalent height of liquid (in a virtual tank) at the full span of the transmitters (at 20mA).

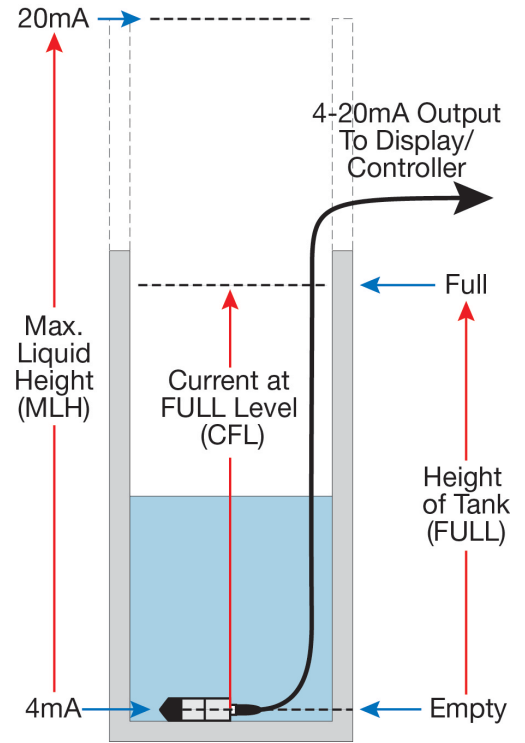

To calculate the **Maximum Liquid Height (MLH)** of a sensor, use the following formulas:

Feet	$MLH = ( PR \times 2.31 ) / SG$
Meters	$MLH = ( PR \times 0.704 ) / SG$

Example: **15 psi** transmitter installed in a liquid with a **SG=0.9** will have the following value(s):

Feet	$MLH = ( 15 \text{ psi} \times 2.31' / \text{psi} ) / 0.9 = 38.5'$
Meters	$MLH = ( 15 \text{ psi} \times 0.704\text{m} / \text{psi} ) / 0.9 = 11.73\text{m}$

- Height of the Tank (**FULL**).
  - For best results, select the highest level of liquid possible in the tank even though you may never reach this level in the tank.
- Current at FULL Level (**CFL**)
  - To calculate the Current at FULL level (**CFL**)
    - $CFL = ( FULL / MLH ) \times 16\text{mA} + 4\text{mA}$

Feet	Where FULL = 10' ... $CFL = ( 10' / 38.5' ) \times 16 \text{ mA} + 4 \text{ mA} = 8.1558 \text{ mA}$
Meters	Where FULL = 3m ... $CFL = ( 3\text{m} / 11.73\text{m} ) \times 16 \text{ mA} + 4 \text{ mA} = 8.0920 \text{ mA}$

The difference in output above is due to the slight difference between 10' and 3m.

- Pump, Valve and Alarm setpoints
  - All set points are in either Feet of Meters of liquid and are measure from the location of the Pressure Transmitter.

## CONFIGURE THE DATAVIEW LI23/LI24 SERIES (METHOD #2):

Use the following steps to configure the DataView™ to match the DeltaSpan™ transmitter:

1. Set UNITS (**unitsS**) to Feet or Meters
2. Set DECIMAL POINT (**dEc Pt**) to dddd.dd
3. Set PROGRAM / SCALE to the following:
  - a. To access all functions for rescaling the current input, you will need to access the display's Full Menu.
  - b. Set Input 1 (**InPt 1**) to 04.000 mA.
    - i. *Default for Input 1 is 04.000, so no changes are required.*
  - c. Set Display 1 (**DSPY 1**) to 0000.00.
    - i. *Default for Display 1 is 0000.00, so no changes are required.*
  - d. Set Input 2 (**InPt 2**) to **CFL** value (in mA).
    - i. *Default for Input 2 is 20.000, so a change is required.*
  - e. Set Display 2 (**DSPY 2**) to **FULL** value (in Feet or Meters).
    - i. *Default for Display 2 is 0200.00, so a change is required.*
4. Set RELAYS (**rELAY**) to liquid levels where the relay will close and open
  - a. Each relay will have a setting where the relay will energize (**SEt #** for relay 1, etc.) and a setting where the relay will de-energize (**RSt #** for relay 1, etc.).
    - i. High alarms – Set **SEt #** at the level for the high alarm and set **RSt #** to a level slightly below the SEt #. This will create a small hysteresis to prevent chatter (i.e. SEt 2 = 8.00' and RSt 2 = 7.90'...this creates a 0.10' hysteresis).
    - ii. Low alarms – Set **SEt #** at the level for the low alarm and set **RSt #** to a level slightly above the SEt #. This will create a small hysteresis to prevent chatter (i.e. SEt 3 = 2.00' and RSt 3 = 2.15'...this creates a 0.15' hysteresis).
    - iii. Valve or Pump Fill - Set **SEt #** at the level for the Valve to Open or the Pump to Start Filling and set **RSt #** at the level above where the valve will Close or the pump will Stop Filling. This will create a unique ON and OFF span (i.e. SEt 4 = 3.00' and RSt 3 = 7.50'...this creates a fill span of 4.50').
    - iv. Valve or Pump Empty - Set **SEt #** at the level for the Valve to Open or the Pump to Start Emptying and set **RSt #** at the level below where the valve will Close or the pump will Stop Emptying. This will create a unique ON and OFF span (i.e. SEt 1 = 7.00' and RSt 1 = 4.00'...this creates a empty span of 3.00').



### CONFIGURE THE DATALOOP™

Use the following steps to configure the DataLoop™ to match the DeltaSpan™ transmitter:

1. Set UNITS (**unitsS**) to Feet or Meters
2. Set DECIMAL POINT (**dEc Pt**) to dddd.dd
3. Set SCALE to the following:
  - a. Set Input 1 (**InPt 1**) to 04.000 mA (*default is 04.000, so no changes are required*).
  - b. Set Display 1 (**DSPY 1**) to +00,000.00 (*default is +00,000.00, so no changes are required*).
  - c. Set Input 2 (**InPt 2**) to CFL Value in mA. (*default is 20.000, so a change is required*).
  - d. Set Display 2 (**DSPY 2**) to Full value (*default is +00,100.00, so a change is required*).
4. Set RELAYS (**rELAY**) to liquid levels where the relay will close and open
  - a. Each relay will have a setting where the relay will energize (**SEt #** for relay 1, etc.) and a setting where the relay will de-energize (**RSt #** for relay 1, etc.).
    - i. High alarms – Set **SEt #** at the level for the high alarm and set **RSt #** to a level slightly below the SEt #. This will create a small hysteresis to prevent chatter (i.e. SEt 2 = 8.00' and RSt 2 = 7.90'...this creates a 0.10' hysteresis).
    - ii. Low alarms – Set **SEt #** at the level for the low alarm and set **RSt #** to a level slightly above the SEt #. This will create a small hysteresis to prevent chatter (i.e. SEt 3 = 2.00' and RSt 3 = 2.15'...this creates a 0.15' hysteresis).
    - iii. Valve or Pump Fill - Set **SEt #** at the level for the Valve to Open or the Pump to Start Filling and set **RSt #** at the level above where the valve will Close or the pump will Stop Filling. This will create a unique ON and OFF span (i.e. SEt 4 = 3.00' and RSt 3 = 7.50'...this creates a fill span of 4.50').
    - iv. Valve or Pump Empty - Set **SEt #** at the level for the Valve to Open or the Pump to Start Emptying and set **RSt #** at the level below where the valve will Close or the pump will Stop Emptying. This will create a unique ON and OFF span (i.e. SEt 1 = 7.00' and RSt 1 = 4.00'...this creates a empty span of 3.00').



A periodic check of system calibration is suggested. The pressure transmitters are not field repairable and should be returned if repair is needed (field repair should not be attempted and may void warranty). Be sure to include a brief description of the problem plus any relevant application notes. Contact customer service to receive a return goods authorization number before shipping.

Maintenance should consist of inspection to see that the transmitter is free from debris and not coated with any substance, which would prevent liquid from freely entering and leaving the transmitter. If this occurs, the transmitter should be cleaned.

**TESTING THE TRANSMITTER:**

- First, verify that the sensor is wired correctly.
- Next, check if the power supply is providing the required power.
- Finally confirm that the loop resistance is not exceeding the sensor’s specification.

If transmitter is not functioning properly, isolate the transmitter from the system and wire as shown below. Multimeter should read 4 mA with the transmitter out of liquid.

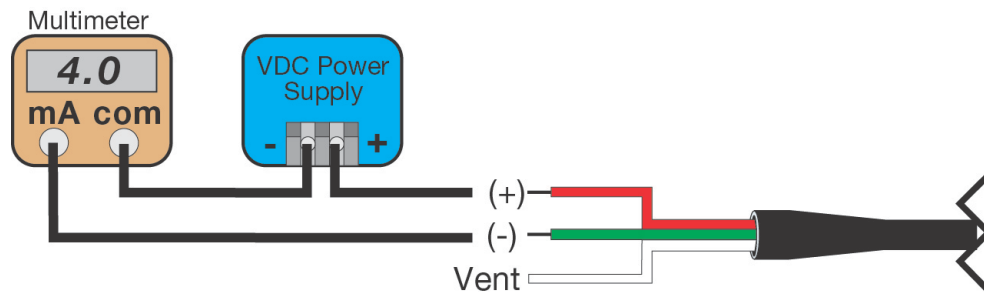

**DESICCANT FILTER (OPTIONAL)**

For extra protection against humidity, add the LD90-3000 desiccant filter, which can be attached to the vent tube.

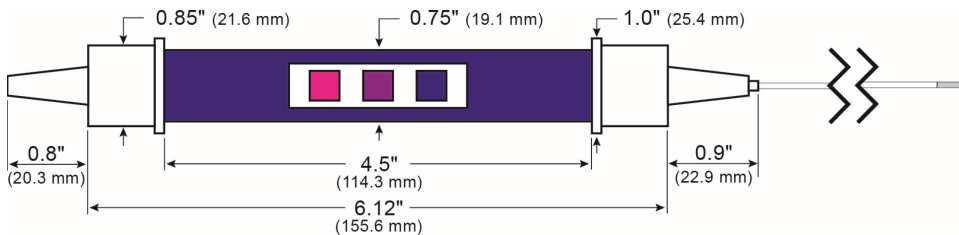

### WARRANTY

Flowline warrants to the original purchaser of its products that such products will be free from defects in material and workmanship under normal use and service in accordance with instructions furnished by Flowline for a period of two years from the date of manufacture of such products. Flowline's obligation under this warranty is solely and exclusively limited to the repair or replacement, at Flowline's option, of the products or components, which Flowline's examination determines to its satisfaction to be defective in material or workmanship within the warranty period. Flowline must be notified pursuant to the instructions below of any claim under this warranty within thirty (30) days of any claimed lack of conformity of the product. Any product repaired under this warranty will be warranted only for the remainder of the original warranty period. Any product provided as a replacement under this warranty will be warranted for the full two years from the date of manufacture.

### RETURNS

Products cannot be returned to Flowline without Flowline's prior authorization. To return a product that is thought to be defective, go to [www.flowline.com](http://www.flowline.com), and submit a customer return (MRA) request form and follow the instructions therein. All warranty and non-warranty product returns to Flowline must be shipped prepaid and insured. Flowline will not be responsible for any products lost or damaged in shipment.

### LIMITATIONS

This warranty does not apply to products which: 1) are beyond the warranty period or are products for which the original purchaser does not follow the warranty procedures outlined above; 2) have been subjected to electrical, mechanical or chemical damage due to improper, accidental or negligent use; 3) have been modified or altered; 4) anyone other than service personnel authorized by Flowline have attempted to repair; 5) have been involved in accidents or natural disasters; or 6) are damaged during return shipment to Flowline. Flowline reserves the right to unilaterally waive this warranty and dispose of any product returned to Flowline where: 1) there is evidence of a potentially hazardous material present with the product; or 2) the product has remained unclaimed at Flowline for more than 30 days after Flowline has dutifully requested disposition. This warranty contains the sole express warranty made by Flowline in connection with its products. **ALL IMPLIED WARRANTIES, INCLUDING WITHOUT LIMITATION, THE WARRANTIES OF MERCHANTABILITY AND FITNESS FOR A PARTICULAR PURPOSE, ARE EXPRESSLY DISCLAIMED.** The remedies of repair or replacement as stated above are the exclusive remedies for the breach of this warranty. **IN NO EVENT SHALL FLOWLINE BE LIABLE FOR ANY INCIDENTAL OR CONSEQUENTIAL DAMAGES OF ANY KIND INCLUDING PERSONAL OR REAL PROPERTY OR FOR INJURY TO ANY PERSON. THIS WARRANTY CONSTITUTES THE FINAL, COMPLETE AND EXCLUSIVE STATEMENT OF WARRANTY TERMS AND NO PERSON IS AUTHORIZED TO MAKE ANY OTHER WARRANTIES OR REPRESENTATIONS ON BEHALF OF FLOWLINE.** This warranty will be interpreted pursuant to the laws of the State of California. If any portion of this warranty is held to be invalid or unenforceable for any reason, such finding will not invalidate any other provision of this warranty.

For complete product documentation, video training, and technical support, go to [www.flowline.com](http://www.flowline.com).

For phone support, call 562-598-3015 from 8am to 5pm PST, Mon - Fri.

(Please make sure you have the Part and Serial number available.)